

World Wide Web Consortium Tenth Anniversary in Asia

W3C10 Asia

Sponsor / Exhibitor

Exhibition Information

October.2006

1. Implementation Overview

Event Name	World Wide Web Consortium Tenth Anniversary in Asia W3C10 Asia
Exhibition date and time	November 28, 2006 (Tuesday) – 12:00 - 17:30
Venue	Hotel Nikko Tokyo 1 st Floor Hall: Sirius Address: 1-9-1 Daiba, Minato-ku, Tokyo 135-8625, Japan Tel +81-3-5500-5500

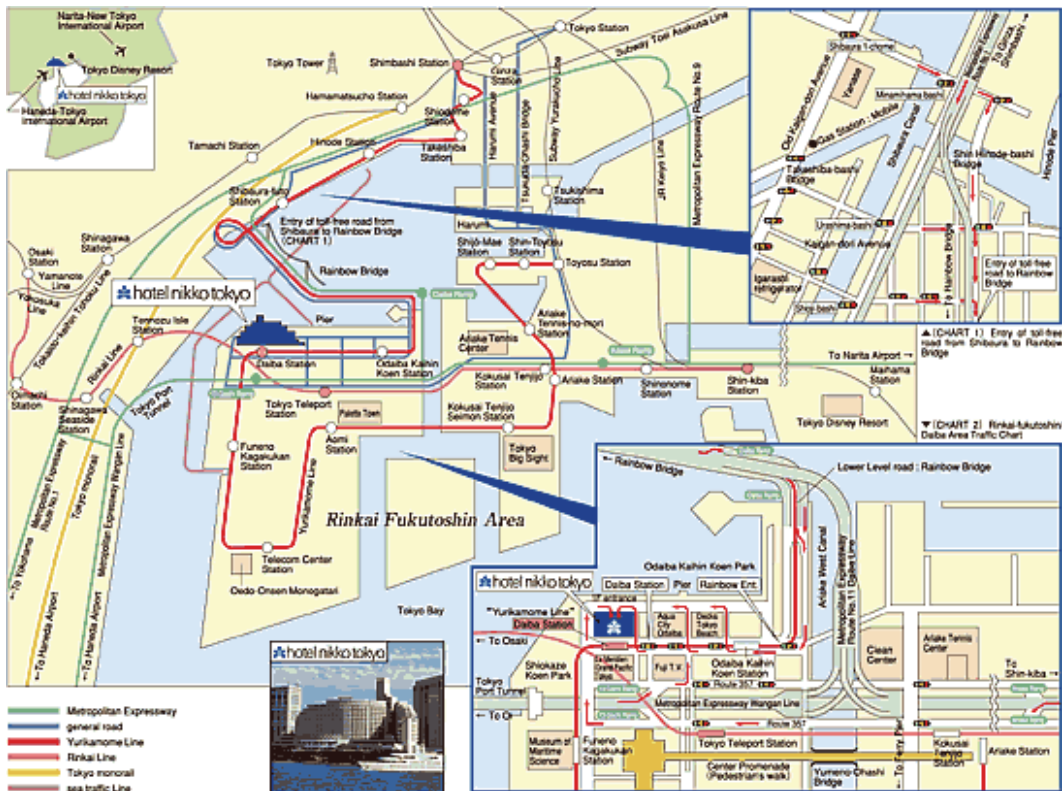

How to Access

The hotel is located at Daiba Station, a 15-minute ride from Shimbashi Station on the new Transit System of Tokyo "Yurikamome". It can also be reached by car from Haneda Airport in about 15 minutes or from Narita Airport in about 50 minutes.

Train

Directly Connected to Daiba Station.

A 10-minute walk from Tokyo Teleport Station.

A free shuttle bus is also operated from Tokyo Teleport Station.

Limousine Bus

The Limousine Bus Arrives at entrance on the first floor of Hotel Nikko Tokyo.

Approximate time requirements

【From NARITA Airport】 75 minutes

【From HANEDA Airport】 20 minutes

2. About the Exhibition Booth

Booth Layout

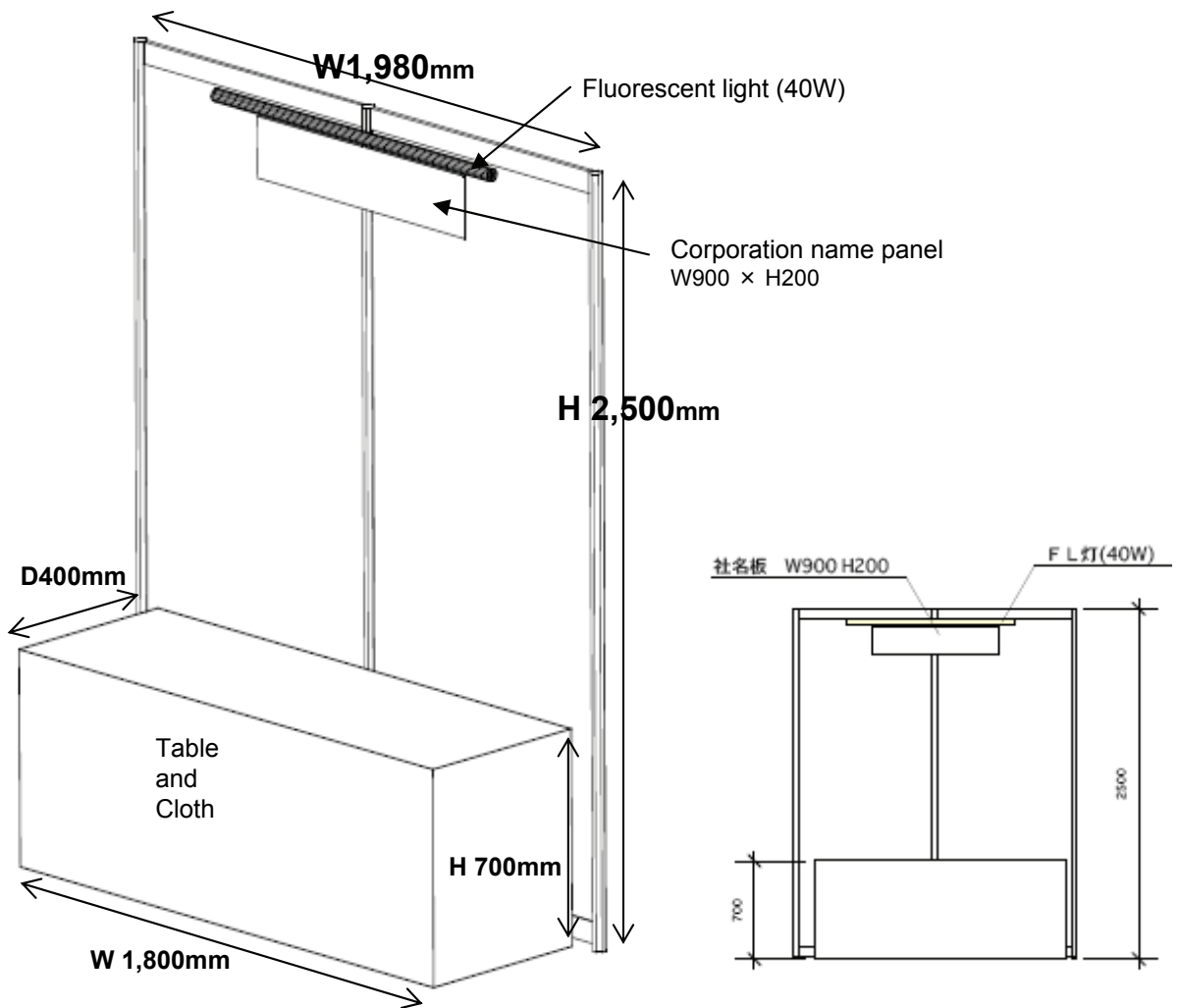

Booth Specifications

The size for one booth: W1,980mm x D600mm x H 2,500mm

■ Besides the above mentioned space dimensions, the following items are also included.

- ① A back panel * The back panel is made of wood with white wallpaper.
- ② 1 corporation name panel (W900mm/H200mm)
* The name panel will be consolidated as the panel base color being white, the text color being black.
- ③ 1 fluorescent light (40W)
- ④ 1 table (W1800mm/D600mm/H700mm) and Cloth.

Basic Booth Furnishings

■ The following furnishings are included in ONE exhibition booth.

- ① Power Supply: 100V/400W x 1 Circuit (1 double Parallel mouth electrical outlets without earth)
※ In the case where more than 2 power connections are necessary, please furnish such needed extension.
※ Please be forewarned that unique power supplies other than 50Hz 100v can not be provided.
- ② Two Chairs



■ The supplement of the above furnishings and the modification of the power supply is handled by the Administration.

■ For such items as PCs needed for demonstrations and/or presentations, each company must provide their own equipment/utilities.

■ Internet Connection

Wireless LAN (802.11a/b/g) will be available at the exhibition hall.

ESS-ID of the wireless basestation will be available at the registration desk of the W3C10 on the 1st floor.

Internet Connection

3. Move-in and Move-out

Schedule

- Exhibitors Move-in : November 28, 2006 (Tuesday) – 10:00 - 12:00
- Exhibit Hall Open: November 28, 2006 (Tuesday) – 12:00
- Exhibit Hall Close: November 28, 2006 (Tuesday) – 17:30
- Exhibitors Move-out: November 28, 2006 (Tuesday) – 17:30 - 18:30

The interior design of the booth

It is requested that each exhibitor do the booth interior design.

In the case of using pre-prepared posters or panels, these can be attached directly to the inner walls of the booth such as the back wall panel. The usage of thumb tacks, pins, and adhesive tapes is possible. (Each exhibitor must provide their own thumb tacks, pins, and adhesive tapes as well as tools needed for the decoration and installation of items.)

The transport of materials and the decoration

<By Car>

One day parking ticket is available **only for exhibitors**.

You may park your car at the hotel parking. Please receive a permit stamp on your parking ticket at the registration desk of the W3C10 on the 1st floor.

<Package>

In the case of sending items, in advance, to be used in the exhibitors booth such as catalogues or small equipment, please send to the following address. Those must be received **on November 27 (Monday)**.

Small packages Destination

【 Small packages Shipping Destination 】

To: Attn. Satoshi Inoue, Manager, Sales & Marketing
"11/28 Hall Sirius W3C10 Asia"

Cloakroom, 1st floor, Hotel Nikko Tokyo

Address: 1-9-1 Daiba, Minato-ku, Tokyo 135-8625, Japan

Tel +81-3-5500-5500

Note: Specify "to be used at the W3C10 Asia", and be sure to state the exhibitor name and the person responsible when you send the packages.

Sample;

To be used at the EXHIBITION of W3C10 Asia

Company Name:

Person responsible:

Tel:

Contents:

About the dismantling and clearing of materials

Dismantling is planned to start at **17:30 on November 28**.

The dismantling and clearing of materials must be completed by **18:30**.

Please be sure not to leave left over materials or waste matter when dismantling and clearing.

4. Information and Notification

Exhibitors Badge

The exhibitors badge is required to enter exhibition room. The exhibitors badge will be distributed at the registration desk.

REGISTRATION DESK

1st Floor, Hall Orion

Hotel Nikko Tokyo

(Open: Nov. 28, 2006, 9:00 am to 5:00 pm)

Other important issues

■ Please give proper heed to the prevention of theft and/or accidents during transport of materials, clearing and during the conference.

■ All sponsors and exhibitors are kindly reminded not to inconvenience other the neighboring Booths at the exhibitions, demonstrations and presentations.

Inquiries Related to the Exhibition booth

【Contact for the inquiries related to the exhibition booth】

Ms. Hiromi Okuda
W3C10 Asia Registration Desk
E-mail: w3c-info@wizgroup.co.jp